

TUBULAR PASSAGE / PRIVACY (20/30) TEMPLATE

IMPORTANT: VERIFY BACKSET BEFORE DRILLING DOOR
BACKSET WILL BE EITHER $2\frac{3}{8}$ " OR $2\frac{3}{4}$ "
DRAWING NOT TO SCALE

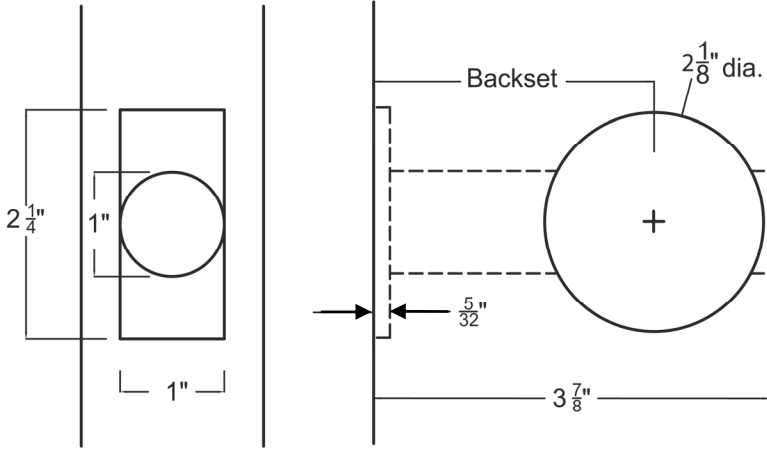

IMPORTANT: VERIFY TYPE OF STRIKE ORDERED BEFORE MORTISING JAMB
STRIKES ARE NOT DRAWN TO SCALE

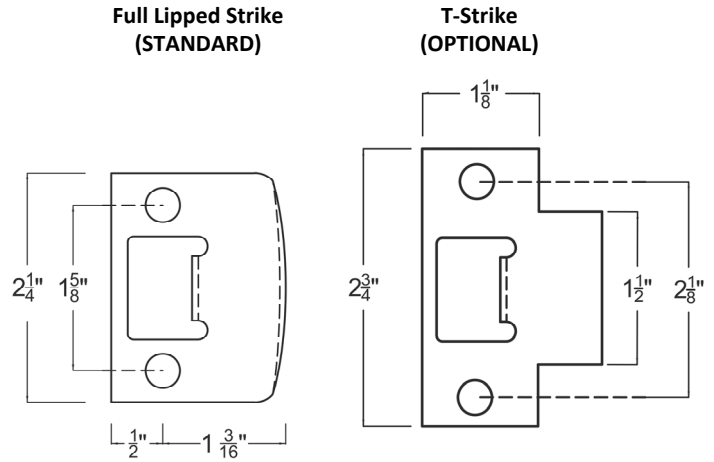

IMPORTANT: VERIFY TYPE OF STRIKE ORDERED BEFORE MORTISING JAMB
STRIKE THICKNESS: $3/32$ " (INCLUDING THICKNESS OF DUSTBOX)

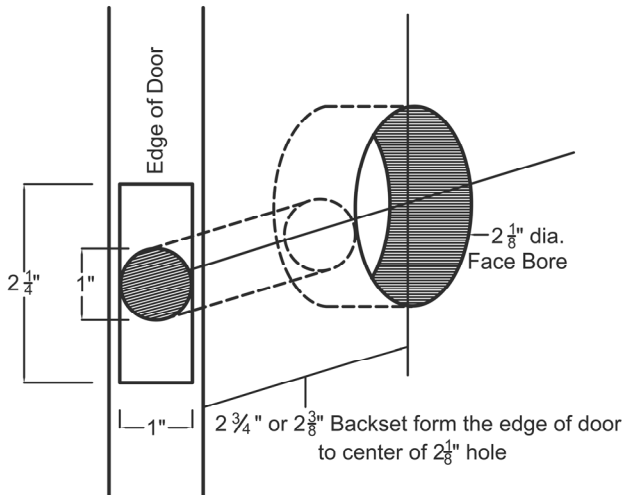

FOR PRIVACY LATCH ONLY, OVAL SPACER MUST
BE INSTALLED FOR CORRECT OPERATION

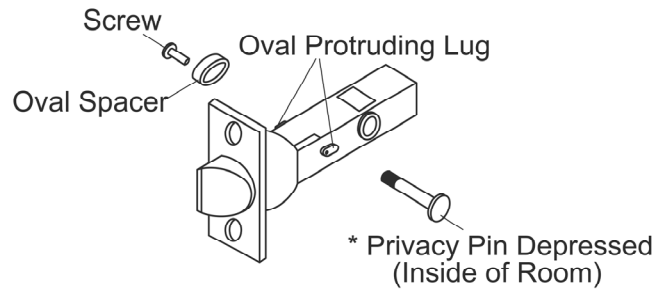

* Note: Thread in privacy button after trim is applied

IMPORTANT: VERIFY TEMPLATE IS PRINTED TO SCALE BEFORE USING AS A DRILLING TEMPLATE

2"

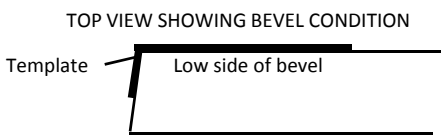

IMPORTANT: IF DOOR IS BEVELLED
LAY TEMPLATE ON LOW SIDE OF BEVEL

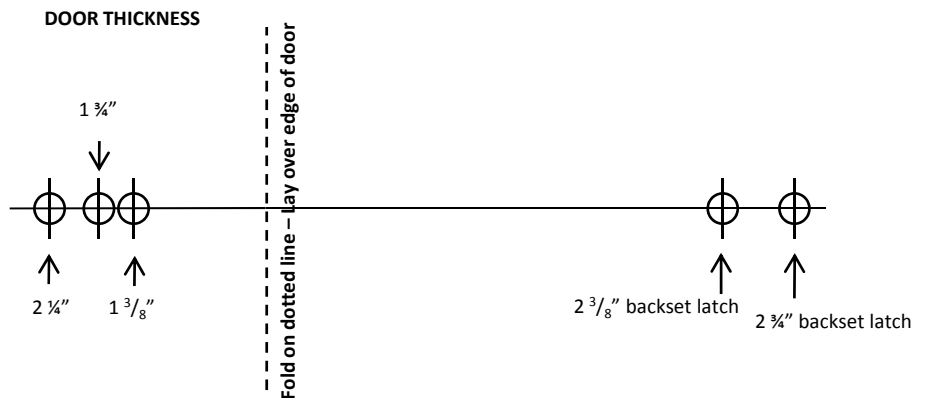

TUBULAR PASSAGE / PRIVACY (20/30) TEMPLATE

DOOR PREPARATION (IF NEEDED)

- Determine latch backset ($2 \frac{3}{8}$ " or $2 \frac{3}{4}$ ")
- Suggested location of passage/privacy set is determined by placing lever $36"$ – $38"$ above finished floor
- Ensure that door stile will accommodate the latch and trim before drilling
- Mark door using template below. If door is bevelled, place folded edge on low side of bevel
- Drill $1"$ dia. edge bore for latch, $3 \frac{7}{8}"$ deep
- Drill $2 \frac{1}{8}"$ face bore. **Note – for wood doors, to avoid splintering, drill a centering hole through the door, then drill face bore from both sides**
- Insert latch in door, with bevelled side facing jamb and trace outline of faceplate and mark screw positions
- Remove latch and chisel out mortise $\frac{5}{32}"$ deep, and drill $\frac{1}{8}"$ pilot holes for latch screws
- Determine proper position for strike, trace outline and chisel to $\frac{3}{32}$ depth (this includes thickness of dustbox)

HANDLE INSTALLATION

- Install latch as described above, ensuring latch bolt is facing the correct way for door opening
 - **FOR PRIVACY LATCH ONLY, OVAL SPACER MUST BE INSTALLED FOR CORRECT OPERATION**
- Fit and insert spindle through latch (with spindle on square orientation)
 - **PRIVACY SPINDLE MUST BE UNWOUND $2 \frac{1}{2}$ COMPLETE TURNS (10 QUARTER TURNS)**
 - **FOR PRIVACY SPINDLE ONLY, GENTLY REMOVE 'O' RING FROM SPINDLE, INSERT SPINDLE INTO LATCH THEN REPLACE 'O' RING TO FIX LATCH INTO PLACE**
- Offer handles onto spindle, ensure plates are straight and square, and secure with screws provided
- For square RE square rose, four small wood screws are provided to anchor the plate to the door. These **MUST** be installed to prevent the rose from rotating out of true (see drawing)
- For privacy sets, insert privacy pin from inside and screw down finger tight

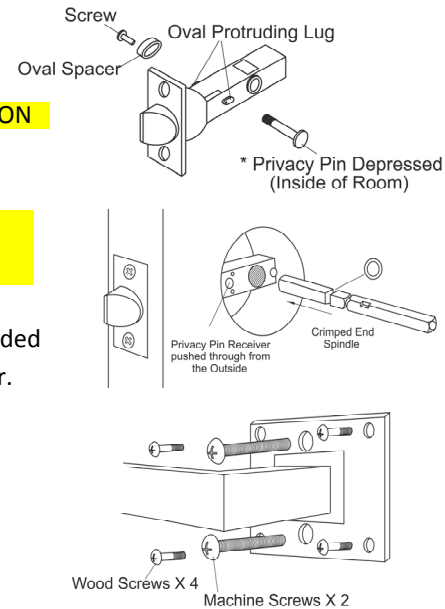

PRIVACY ONLY – TEST FUNCTION AND EMERGENCY RELEASE

- Press pin to locked position. Outside lever should be locked. Inside lever should operate, unlocking door and retracting latch
- Test emergency release – with pin pushed in and outside lever in locked position, insert a short pointed object (e.g. nail) into emergency release hole from outside. This should release the outside lever and allow the door to be opened
- Test anti-lockout feature – with door open, push pin to lock outside lever. Press latch bolt in with thumb. The privacy pin should pop out to the unlocked position, releasing the outside lever and avoiding a "lock-out" from the room

TROUBLESHOOTING

- If lever is binding, in many cases, slightly loosening the screws will free up the levers
- Ensure product is square and straight on both sides

IMPORTANT: VERIFY TEMPLATE IS PRINTED TO SCALE BEFORE USING AS A DRILLING TEMPLATE 2"

